

**Product Datasheet model uvex megasonic 9320 500**

**UVEX ARBEITSSCHUTZ GMBH, Würzburger Str. 181-189,  
D-90766 Fürth**

**1. Product Characteristics****1.1 General features**

- functional safety goggle in ski goggle design with a truly panoramic field of vision
- unique frameless lens design for edge-to-edge optical clarity and increased safety
- soft, adaptive face seal providing a universal fit for different head and facial shapes as well as a tight fit without pressure points
- generous internal volume to accommodate prescription spectacles and frame recesses to locate the side arms ensuring a comfortable fit
- indirect ventilation system increases air circulation
- length-adjustable 30 mm wide silicone headband for optimal low pressure hold and individual adaptability
- robust polycarbonate lens with uvex's proven supravision coating technology – permanent anti-fog and scratch-resistant lens
- UV400 – 100 % protection against dangerous UVA and UVB radiation up to 400 nm
- metal-free

## 1.2 CR – autoclavable safety eyewear

- first autoclavable protective safety eyewear with anti-fog performance
- sterile eye protection in every situation – therefore suitable for cleanroom environments
- suitable for autoclave sterilization – 20 cycles at 121°C for 20 minutes each

## 1.3 Disinfection

- commercially available disinfectants (Ethanol/Isopropanol up to 70%) can be used – either by spraying or wiping
- goggles should not be placed in disinfectant for an extended period of time
- machine cleaning in the pre-wash process is also possible

## 2. Technical Details Body

### Frame

Material	TPE
Colour	transparent, white

### Headband

Material	silicone headband
Features	individual adjustable
Colour	transparent, white

### Marking

Manufacturer´s ID code	W
Applicable EN norm	166
Field of use	3 (drops and splashes of liquid) 4 (large dust particles)
Impact resistance	F (45 m/s)
Conformity symbol	CE

### 3. Technical Details Lens

Material	PC
Thickness	2.4 mm at PD
Coating	uvex supravision clean
Colour	clear
UV protection	UV400
<b>Marking</b>	
Filter	2C-1.2 (EN 170)
Manufacturer 's ID code	W
Optical class	1
Impact resistance	F (45 m/s)
Scratch resistance	K
Antifog	N
Conformity symbol	CE
Factory symbol	

## 4. Logistical Information

### Product

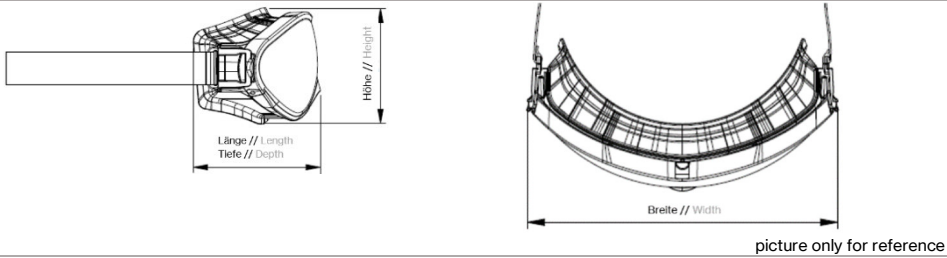
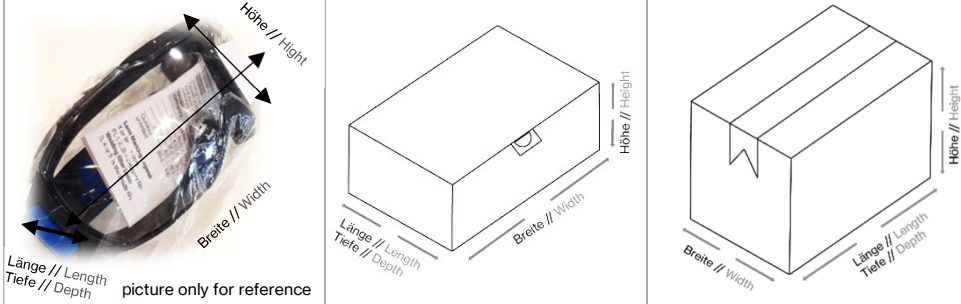
Weight	107g		
Dimensions (L x W x B) in approx. mm			
	85 x 193 x 85		
	<b>Packing unit 1</b>	<b>Packing unit 2</b>	<b>Packing unit 3</b>
EAN Code	4031101958231		
Quantity in pcs.	1	4	64
Dimensions (L x W x H) in approx. mm			
	85 x 193 x 85	185 x 290 x 97	600 x 400 x 400
Net weight in approx. g	107	428	6,848
Gross weight in approx. g	125	610	10,620
Country of Origin	Germany		

## 5. Miscellaneous

Standards	EN 166 + EN 170
PPE Category	Category II